

Remote Kits on GS Trailers produced after 11-15-18

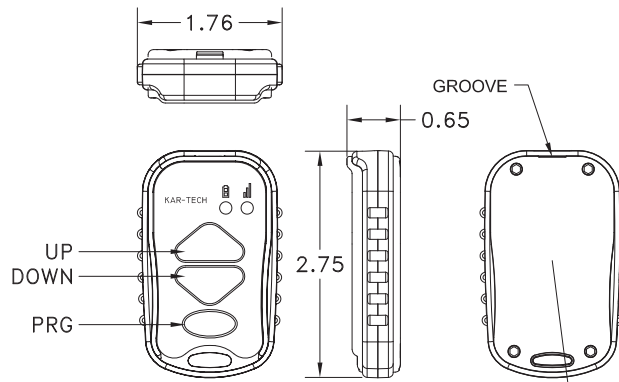

TRANSMITTER
P/N: 3A3232A

TO REPLACE THE INTERNAL CR2032 DISPOSABLE BATTERY, REMOVE 4 ALLEN SCREWS USING A 5/64" ALLEN WRENCH. LIFT BACK COVER USING GROOVE. DO NOT OVER TIGHTEN THE SCREWS WHEN RE-ASSEMBLING BACK COVER.

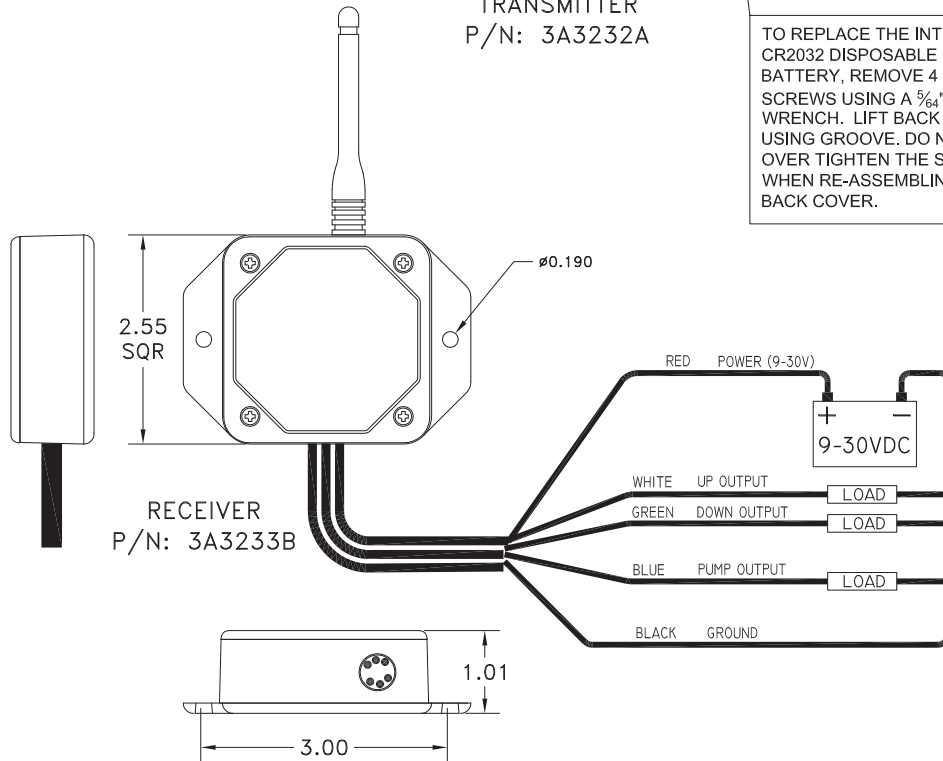

RECEIVER
P/N: 3A3233B

OPERATION

- Press any button to begin operation. This will turn on the transmitter and turn on the selected output at the same time. The transmitter remains on for additional 3 seconds after button is release and then turns off automatically.
- The green LED light on the transmitter will blink 2 times per second when the transmitter and receiver are communicating. It will blink 1 time per second if there is no communication (i.e. - no power to the receiver)
- The red LED light on the transmitter will blink if the battery is low and should be replaced.

SYNCHRONIZING TRANSMITTER AND RECEIVER

Each radio remote system is designed to operate with a unique radio ID code and RF channel sequence. Each receiver is programmed to respond only to the transmitter with the correct ID code/RF channel sequence. This feature allows multiple systems to work in close proximity to one another without interference. In the event that a transmitter becomes damaged and a new one is needed, the receiver can be reprogrammed to respond to the new transmitter. To teach the ID code to the receiver, use the following procedure:

1. Make sure the receiver and transmitter are OFF. **Power to the red wire must be disconnected. We recommend disconnecting the pump battery.**
2. Press and hold UP and PRG buttons for five seconds until both LEDs start blinking then release buttons.
3. Apply power to the receiver. **Reconnect the battery**
4. Wait for ~5 seconds or until the green LED on the transmitter starts blinking rapidly.
5. Teach complete.

CLONING TRANSMITTERS

WARNING! - This feature can pose a safety hazard for operators if both transmitters are used simultaneously- use with CAUTION!

Occasionally, it is desirable to have more than one transmitter work with a single receiver. This is accomplished by a process called cloning. Cloning allows an additional transmitter (B) to have the same ID code as the original transmitter (A). If this feature is desired, use the following procedure:

1. Make sure both transmitters and the receiver are off
2. On Transmitter A, press and hold UP and PRG buttons for five seconds until both LEDs start blinking then release buttons
3. On Transmitter B, press and hold UP and DOWN buttons for five seconds until both LEDs start toggling then release buttons
4. Wait for ~5 seconds until the green LEDs start blinking rapidly
5. Cloning complete

If the cloning feature has been invoked and is no longer desired, the ID code of one of the transmitters needs to be changed. This will undone the transmitters. If this is desired, use the following procedure:

1. Make sure the receiver and transmitter are OFF
2. Press and hold UP, DOWN and PRG buttons for five seconds until both LEDs start toggling then release buttons
3. Press any button again to select a new ID
4. uncloning complete
5. Follow the SYNCHRONIZING TRANSMITTER AND RECEIVER procedure above to link the undoned transmitter to a new receiver

RECEIVER OPERATION MODES

Kar-Tech NANO remote system can operate in two different modes:

Mode 1: Pump output turns on when UP or Down output is turned on.

Mode 2: Pump output turns on when UP output is turned.

The factory default is Mode 1. To change the mode use the following procedure:

1. Turn the receiver and transmitter OFF
2. Press and hold Down and PRG buttons for five seconds until the red LED starts blinking. Release buttons
3. Turn the receiver on
4. Press UP button for Mode 1 and DOWN button for MODE 2
5. Mode programming complete

SPECIFICATIONS

Power:

- Transmitter: CR2032, 3V Lithium battery
- Battery life: 15 hrs of operation
- Receiver: +9VDC to +30 VDC

Receiver solid state output rating: 5A each (sourcing), 20A system maximum

RF: 902-928MHz FHSS 4mW

Environmental:

Operating temperature:

- Transmitter: -20 to +60°C
- Receiver: -40 to +85°C

Ingress Protection:

- Transmitter: IP64
- Receiver: IP65

This device complies with Part 15 of the FCC Rules. Operation is subject to the following two conditions: (1) this device may not cause harmful interference, and (2) this device must accept any interference received, including interference that may cause undesired operation.

Changes or modifications not expressly approved by Kar-Tech will void the user's authority to operate the equipment.